

International Journal of
Engineering Research and Science & Technology



ISSN : 2319-5991

www.ijerst.com

Email: editor@ijerst.com or editor.ijerst@gmail.com

This article can be downloaded from <http://www.ijerst.com/currentissue.php>

SMARTHOMESERVICESYSTEMBASEDANIOT

Dr.V.SivaNagaraju¹,SwapnaBadabaji²

Abstract: Every aspect of our lives is becoming simpler and easier as a result of the advancement of automation and technology. Automated systems are much more popular than manual ones. Despite our hectic schedules, the Internet of Things is a growing network of common objects, ranging from mechanical devices to consumer items, that can exchange data and perform tasks. Wireless home automation systems employ computers or mobile devices to operate the functions and features of the home, which means that electricity and human energy are saved.. The term "smart home" refers to a system in which all of a home's electronics may be controlled from afar. We'll use the Internet of Things (IoT) to control our home appliances in this project. We can also get a range of temperature, fire, and gas by employing various sensors that are sensed by the controller and displayed on the LCD. This occurs after receiving a GSM notification that the range of provided values has been expanded. It's also saved on the server for future reference to these variables.

KEYWORDS:Internet of Things, Wireless SensorNetwork(WSN) (IoT).

INTRODUCTION

The NXP ARM7-LPC2148 development board is the architecture of the complete system because of its versatility in processing and communication. It doesn't matter where the sensors are placed. These sensors collect physical data and turn it into a useful signal. Sensors receive signals from the microcontroller, which connects with other devices. Data from the LPC2148 board is used to measure temperatures. The sensors' output is analog, and an ADC7928 analog to digital converter is used to convert it to digital.

Once the sensor gets the signal from the microcontroller it reads the values and displays on the LCD and sends the message through GSM. The GSM will communicate with the processor via a network and SMS-based appliance control. This modem is always monitoring the signals coming in from the

input.. Microcontrollers are notified when a modem receives a text message from an operable phone. This data is compared to previously recorded data by this microcontroller. The microcontroller generates control signals for the load if the compared data match the previously stored values. When a fire or gas leak is detected, this provides a concise overview of how to implement home safety measures. Whenever the LPG concentration in the air rises above a certain level, the Gas sensor will detect the leak and send an SMS to the user's mobile phone and activate the Buzzer alarm and show the message on the LCD screen to alert the people at home. Similarly, when a fire is detected, the sprinkler motor will be automatically activated by sending an SMS message.

¹Professor of Electronics and Communication Engineering, Institute of Aeronautical Engineering, Hyderabad, India.

²PG Student, Department of Electronics and Communication Engineering, Institute of Aeronautical Engineering, Hyderabad, India.

II. LITERATURE REVIEW

The term "wireless sensors" refers to sensor networks that do not need wires. The wireless sensor actuator network (WSAN) is a different form of network that uses distributed sensors to keep tabs on things like sound, pressure, temperature, and so on. Nodes and a gateway are dispersed throughout the network of wireless sensor networks. The gateway is a conduit through which data from sensor nodes can be sent out into the wider world. Sensor activity can also be enabled through the use of current, bidirectional networks. Previously, these networks could only be used for military surveillance on the battlefield, but now they may be used for a wide range of other purposes, including industrial monitoring, health monitoring, and more. An Ad-hoc network is formed when a

microcontroller communicates with all of the sensor nodes, resulting in a network known as a "distributed sensor network." node.

III. EXISTING SYSTEM

People usually are outside the home for many reasons like travelling and they want to You can remote-control some devices from afar. There are a number of electronic gadgets that people would like to be able to manage from a distance, such as lights and thermostats.

IV. PROPOSED SYSTEM

A GSM message will be sent if the temperature, fire, or gas levels fall outside of a predetermined range in this proposed system. LCD displays these values as well. In the web server, the data that has been loaded can be retrieved from any location in the world.



FIG.2. TEMPERATURE SENSOR.FEATURES:

- Operates from 4V to 30V.
- Less than 60µA current drain.

weak DC signal from the ac power provided to the ignitor via flame rectification in the polarity of the electricity.
through a flame rectified DC. The fire sensor

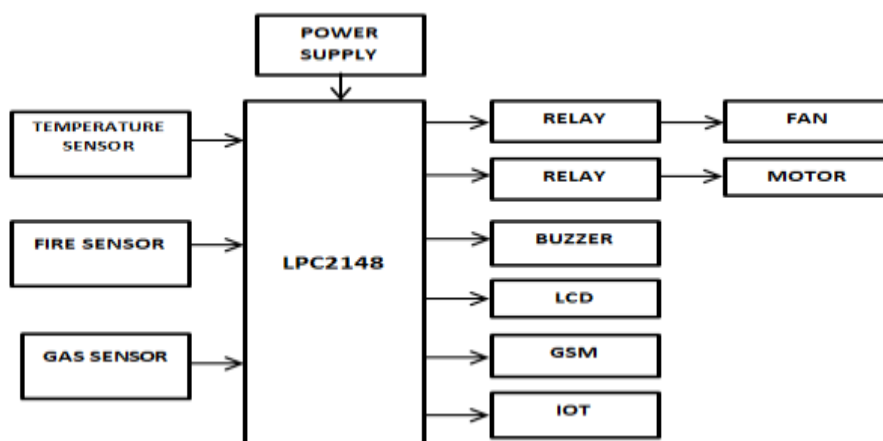

FIG.1.BLOCKDIAGRAM.

V. METHODOLOGY

consists of IR sensor, comparator and LED. It candetect the flame or wavelength at 760 nm range oflight. The fire sensors are designed to provide earlywarning of a fire, involving ordinary combustiblematerials which are expected to progress throughdistinctincipientandsolderingstages.Th etypevolume and density of smoke produced during thefire development processwill vary depending onthefuelsinvolvedandtheamountofoxygenpr esent.Thelighterthetestflamedistanceis,the

A)TEMPERATURE SENSOR:

Temperature

greaterthedistancetest..Itisconnectedtomotor

sensor essentiallymeasures theheat/colddevelopedbyanobjectforwhichitis connected.This is via microcontroller,sowhenthefireisdetectedth emotor sprinklerwillautomaticallyONandalerts by interfacedwith the ADC and thento the sendingmessagetoparticularemobil. microcontroller. The ADC required to interface canbe10or12bitADC.Ifthetemperatureis0°C,th entheoutputvoltageisalso0V.Itthenimplement saproportionalresist ncecurrentorvoltageasoutput.Theoutputofsen sorwhichis convertedto digitaliseasyto connect with microcontroller.LM35isawell-knownlowcosttemperaturesensorwhichisdirec tlycalibratedin DegreesCelsius,meaningthatthe

ut
FI
di

FEATURES:

- Theworkingvoltageis3.3 Vto5V.
- HighsensitivityIRsensor.
- Extremelysensitive towavebetween760-1100nm.

C) **GAS SENSOR:**The gas detector detects thepresenceof gases in an areaas a partof safetysystem.Using MQ Sensor for detecting the gas isvery easy. You can either use the digital or analogpin to accomplish this. Power the module to 5v andnotice the power led on the module to glow andwhen the gas is not detected the output led willremainoffandthedigitalpinwillbe0v.Nowintroducethesensortosomeheat,thentheoutput

FEATURES:

FIG



led to go hiUse the potentiometer to increase the output if necessary. Based on its quick response time, it can detect H2, LPG, Smoke, and Propane. Sensors detect dangerous gas leakage. When gas is found, an alarm is used to notify the public. Gas sensors such as MQ2 offer analog voltage output after sensing the presence of volatile gases in the air..



1 = Output
2 = Vcc (positive voltage)
3 = Gnd

FIG4.GASSENSOR.

FEATURES:

- OperatingVoltageis+5V.
- Smallsensitivitytoalcholandsmoke.
- Fastresponsetimeis<10s.
- Simpledrivecircuit.
- GSM: The global standard for digital cellular communication is the global system for mobile communications. Its primary purpose is to transport speech traffic. A 51- and 26-frame structure is employed in this design. 9.6 kbps of maximum data rate is supported by this device. Messages are exchanged between the microcontroller and the user using the GSM. The frequency is divided into time slots by TDMA. The same frequency channel can be shared by multiple mobile users in a GSM network. GSM phones need a SIM card to identify the user's account. Lowpowerconsumption.
 - Smallestsizedesignedfortinyarticles.
 - Powersupplynominal3,8V.
 - Echocancellationandnoisereduction.



D) WI-FI:TheESP8266EX is the series of this module. Using this, all of the electronic devices can communicate wirelessly with each other across the network of the computer As a result, it is well-suited to today's increasingly interconnected world. All WIFI network tasks can be offloaded from another application processor, but not the application itself, because of its comprehensive networking. In order to send and receive data, UART is used. The SBUF register is used to communicate with the MAX232. The interrupt on the controller is what grabs the serial data. GND, Tx, GPIO2, CH EN, GPIO, RESET, Rx, Vcc are listed as the pins.

FIG 6.WI-FI MODULE.FEATURES:

- I²C(softwareimplementation).

- 16GPIOpins.
- Lowpower operation.
- DataRate:1&2Mbps.

VI. FLOWCHART

VII. RESULTS

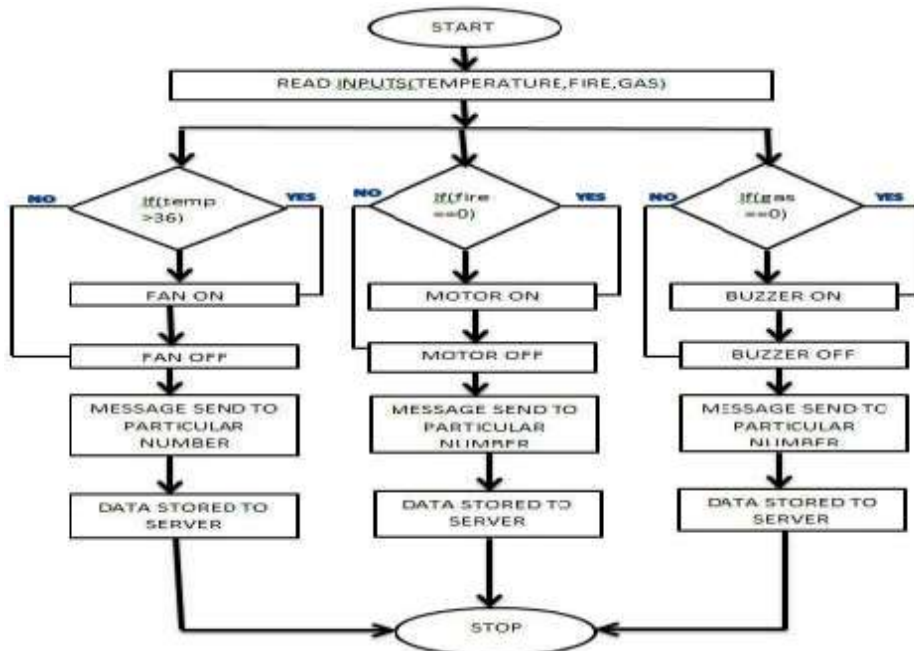

LPG, FIRE, and TEMPERATURE were included in the overall system design and testing.



Potentiometers can also be used to modify the output voltage of gas, fire, and temperature sensors. If a given threshold is crossed, information is transferred through GSM to a certain mobile phone, which shows the data on an LCD screen. Also, if a certain temperature or a fire is detected, the fan or sprinkler will be activated. The buzzer will sound when gas is detected.

FIG 7. GAS SENSOR VALUES DISPLAYED ON LCD

FIG 8. TEMPERATURE SENSOR VALUES DISPLAYED ON LCD

FIG9.GSMOUTPUT

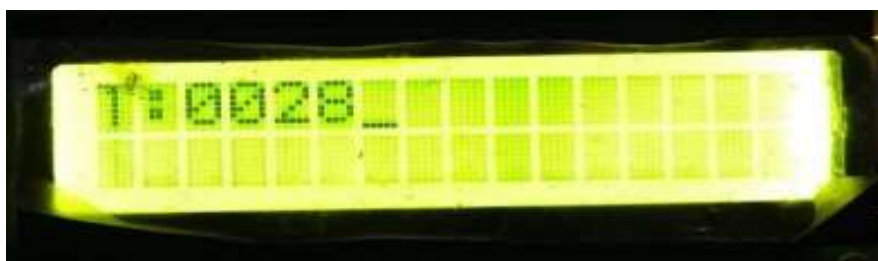

FIG10.DATABASEOUTPUT

[Switch to Graph View](#)

Page 12 of 92 [Next](#)

S1	S2	S3	S4	Date
FIRE_DETECTED				2018-04-09 20:35:22
TEMP_DETECTED				2018-04-09 20:34:36
GAS_DETECTED				2018-04-09 20:33:58
GAS_DETECTED				2018-04-09 20:08:24
FIRE_DETECTED				2018-04-09 20:07:53
TEMP_DETECTED				2018-04-09 20:07:13
TEMP_DETECTED				2018-04-09 20:03:29
TEMP_DETECTED				2018-04-09 19:54:55
FIRE_DETECTED				2018-04-09 19:37:54
FIRE_DETECTED				2018-04-09 19:34:59
GAS_DETECTED				2018-04-09 19:34:12
FIRE_DETECTED				2018-04-09 19:17:08
GAS_DETECTED				2018-04-09 19:16:36
GAS_DETECTED				2018-04-09 19:16:09
GAS_DETECTED				2018-04-09 19:15:10
GAS_DETECTED				2018-04-09 19:14:39
FIRE_DETECTED				2018-04-09 19:14:12
GAS_DETECTED				2018-04-09 19:13:43
GAS_DETECTED				2018-04-09 19:13:05
GAS_DETECTED				2018-04-09 18:05:07



VIII. CONCLUSION

IoT technology is used to improve safety standards in this article, as well. The wireless

interface between transducers and the sensor network on a single chip solution is

This article can be downloaded from <http://www.ijerst.com/currentissue.php>

accomplished through the use of a WI-FI module. Sensors for gas leak detection, fire detection, and temperature increase have been implemented using IoT technology, which has alerting methods for involving and delivering texts to the appropriate individuals

REFERENCES

[1] In the oil, gas, and resource industries: applications of wireless sensor networks (AINA), 2010 24th IEEE International Conference on, M. R. Akhondi, A. Talevski, S. Carlsen, and S. Petersen, IEEE, 2010, pp. 941–948.

[2] Robotics for Risky Interventions and Environmental Surveillance: Proceedings of the EURON/IARP International Workshop on Robotics for Risky Interventions and Surveillance of the Environment, Benicassim, Spain, 2008.

[3] Q. Han, A. A. Ayoade, and J. P. H. Steele

[4] "Development of an oil and gas refinery inspection robot," ASME, pp. 1–10, M. R. Sweatt, W. A. Yearsley, and D. P. Albert, 2014.

[5] M. Bengel, "Mobile Robots for Offshore Inspection and Manipulation," in Intelligent Robots and Systems, 2009. [4].

[6] [5] "A survey on vertex coloring difficulties," E. Malaguti and P. Toth,

[7] Journal of International Transactions in Operational Research

[8] The art gallery theorem: Its variations, applications, and algorithmic elements [6] A. Aggarwal Doctoral dissertation, Johns Hopkins University, 1984.

[9] D. Plets, W. Joseph, K. Vanhecke, E. Tanghe, and L. Martens, "On Coverage Prediction and Optimization Algorithms for Indoor Environments," EURASIP Journal on Wireless Communications and Networking, vol. 2012, no. 123, 2012.

[10] J.-m. Gorce, "On predicting in-building WiFi coverage with a fast discrete approach," Guillaume de la Roche, *Katia Jaffrès-Runserand," vol. 2, no. 1, 2007.

[11] A. R. T.-c. Chiueh, "Deployment issues in enterprise wireless lans," 2003.

[12] J. Yick, B. Mukherjee, and D. Ghosal, "Wireless sensor network survey," Computer Networks, vol. 52, no. 12, pp. 2292–2330, Aug. 2008.