



International Journal of Engineering Research and Science & Technology

ISSN : 2319-5991
Vol. 7, No. 3
August 2018



www.ijerst.com

Email: editorijerst@gmail.com or editor@ijerst.com

Research Paper

REPAIR AND REHABILITATION OF DISTRESSED STRUCTURES INCLUDING INDIAN CASE STUDIES DUE TO DETERIORATION OF CONCRETE AND STEEL CAUSED BY ENVIRONMENTAL AND OTHER FACTORS

Subhendu Das^{1*}

*Corresponding Author: Subhendu Das ✉ sudheers828@gmail.com

Received on: 18th June, 2018

Accepted on: 29th July, 2018

The civil engineering fraternity of the nation is facing a unique challenge today, as on one side there is considerable development of new infrastructure in the country and on the other hand we have substantial quantum of structures of either old vintage or within their service life, which are showing symptoms of structural distress. Inexperienced engineers often inadequately address the issue, as the subject does not always get the necessary impetus in the training curriculums. The concept of Rehabilitation/ Retrofitting is still perceived in the exclusive domain for Earthquake protection. There are text book knowledge of the old practices but are required to be updated with the new techniques, materials and case studies to provide the necessary references to the executives on ground. In the subject paper the impetus is on Repair and Rehabilitation of the distressed structures where deterioration is caused due to old age, environmental factors and inadequate quality control during the construction. The suitable materials and prevalent techniques are introduced, and thereafter four different case studies are discussed in detail (symptoms, investigation and remedial measures), at different geographical locations in India and of different vintage.

Keywords: Distressed structures, Rehabilitation, Earthquake protection, Deterioration

INTRODUCTION

Apart from meeting the various load bearing capabilities, the concrete structures are also expected to perform satisfactorily on the parameters of serviceability, throughout their

service life. The philosophy of preventive maintenance, Repair, Rehabilitation and Retrofitting in their logical sequence is growing in focus, in the worldwide concrete industry, as it is being progressively realized around the world that

¹ Lieutenant Colonel, College of Military Engineering (CME), Pune 411031, India.

we have substantial quantum of concrete structures of either old vintage or those showing signs of distress and premature deterioration prior to the end of their designated life cycle. The cost implication of such restoration works is substantial and there is a constant requirement to familiarize, assess and evolve the various methodologies and materials used for purpose across the world with a view to apply same in the Indian context.

IMPORTANCE OF RECORDS

The repair/rehabilitation and retrofitting of the distressed structures require more cautious approach and experienced supervision. In certain advanced countries there are proper records maintained of such indicative parameters and similar procedures are required to be adopted in the developing countries including India. Points suggested to be included are:

- Structural defects and symptoms observed
 - Cracks o Spalling
 - Corrossion
 - Deflection in structure
- Details of Structural Repairs/ Rehabilitation carried out with methodology adopted, materials used and cost effect.
- Efficacy of the measures undertaken.

In the absence of such procedures, the symptoms are 'covered' and the root cause of the distress and the efficacy/implementation of alternate corrective measures are obscured. Such procedures are recommended to be first implemented for the cutodians of the Public buildings like, PWD, MES, Municipal Corporations, etc.

KNOWN FACTORS OF DETERIORATION

There are numerous well known factors which causes premature distress in the concrete structures. Major common factor however noticed is the corrossion of the structural steel and associated reduction in the cross section of the steel elements, which once commenced leads to progression at a slow pace till it affects the structural stability of the building. The factors aiding faster corrossion are also well known like improper compaction and curing at the construction stage, presence of deteriorating agents like chlorides, sulphates and carbon di oxide in the environment and high humidity and high temperatures or larger diurnal changes in the ambient temperature. There have also been numerous cases wherein the loading pattern has been changed beyond the design loads over a

Figure 1: Corrossion in Rebars



period of time especially in the densely populated residential areas of the metro cities.

MATERIALS FOR REPAIR AND REHABILITATION

Polymer

Since their advent for usage in concrete in 1960s, Polymers, which basically comprises of repeating structural units, has today graduated to the extensive use as admixtures, sealants and bonding agents. Their utility in the field of repair and rehabilitation of the distressed structures has been found noteworthy.

The variants in use in the subject field are:

- Ethylene Vinyl Acetate copolymer
- Styrene Butadiene copolymer
- Acrylic Resins

Carboxylated Styrene Butadiene copolymer latex admixture, commonly known as SBR latex has been found particularly effective and results in higher strength, resilience, impermeability and

resistance to carbonation and chloride ion permeation.

The desired characteristics of polymer are as under:

pH > 7.5

28 D Flexural strength $\geq 50 \text{ Kg/cm}^2$

3 D Compressive Strength $\geq 150 \text{ Kg/cm}^2$

28 D Compressive Strength $\geq 350 \text{ Kg/cm}^2$

28 D Split Tensile strength $\geq 25 \text{ Kg/cm}^2$

The Polymer concrete composite display substantial increase in strength and modulus of elasticity. However despite their frequent use, the updation of the codal provisions for the same is not keeping pace with the introduction of the newer and better products in the market. There is a need to formalize standard evaluation techniques and general guidelines for these products.

Epoxy

Epoxy resins, also known as polyepoxides, are a class of reactive prepolymers and polymers which contain epoxide groups. Epoxy resins may be reacted (cross-linked) either with themselves

Figure 2: Styrene Butadiene Copolymer



Figure 3: Application of Polymer Modified Mortar (PMM)

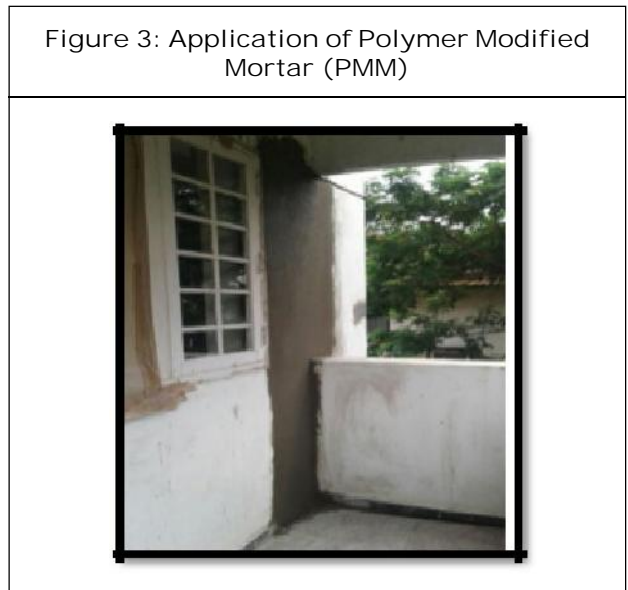

through catalytic homopolymerisation, or with a wide range of co-reactants. These co-reactants are often referred to as hardeners or curatives, and the cross-linking reaction is commonly referred to as curing. Reaction of polyepoxides with themselves or with polyfunctional hardeners forms a thermosetting polymer, often with favorable mechanical properties and high thermal and chemical resistance. Epoxy has a wide range of applications including use in pressure grouting of micro cracks and fissures.

DIFFERENCE BETWEEN REPAIR, REHABILITATION AND RETROFITTING

During the service life of structure, there are various symptoms of distress which are observed due to failing of one or the other component of the structure. It may be a minor sign like peeling off of the plaster on the external walls or serious ones like wide cracks appearing on the wall due to differential settlement in the foundation.

Figure 4: Commercial Epoxy Compound

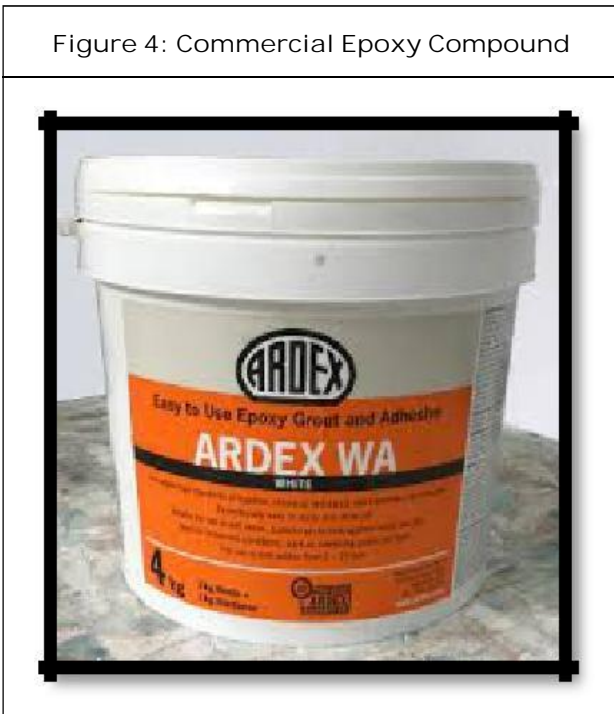

Primarily they can be classified as structural or non-structural nature, with the former warranting more immediate attention in the inter se prioritisation.

Apart from the preventive maintenance, the Repair and Rehabilitation are carried out to address structural distress symptoms and are termed in the similar sequence and priority, based on how serious a threat it is to the structural stability of the building.

Retrofitting, also called 'strengthening', is a technical option for improving the strength and other attributes of resistance of buildings to seismic and other forces, including, deficiencies in design noted due to updation of code provisions, deterioration of concrete in foundation due to settlement of soil strata or weathering effect, etc.

While Retrofitting the elements are planned in a manner that the vibrations and the resultant inertial forces are transferred to the members which are able to resist them. They can be new elements like shear walls, bracings, etc., or strengthened old members with the help of methods explained subsequently.

VARIOUS TECHNIQUES IN VOGUE

This section brings out certain proven and accepted techniques which can be applied for Repair, Rehabilitation and Retrofitting, depending on the severity of the structural distress observed.

Polymer Coating

Polymer coating are resorted to on the concrete surfaces, where the damage is either superficial and/ or indicating future possible ingress of the deteriorating agents like air, harmful chlorides and sulphates.

Figure 5: Polymer Surface Coating



It results in sealing of the microcracks and are required to be applied periodically (normally at an interval of 5 years).

Epoxy Mortar/Grouting

Used on the runway slabs and underside of floor/ roof/sunshades, if the damage is within 75 mm of depth. Having the property of gaining strength within a few hours and substantial impermeability towards chloride and sulphate attacks, they can be alternatively utilized for grouting of hairline cracks by injecting them with pressure.

STRENGTHENING OF FOUNDATION

Strengthening of foundations are resorted to as the supporting soil strata shows inadequate load bearing capacities or under exceptional circumstances, for buiding of additional floors to increase floor to area ratio.

Prior to the Retrofitting of Foundation, the structure load is supported with the process called Shoring. The most important methods of

Figure 6: Epoxy Grouting Arrangement for Column, Beam and Slab

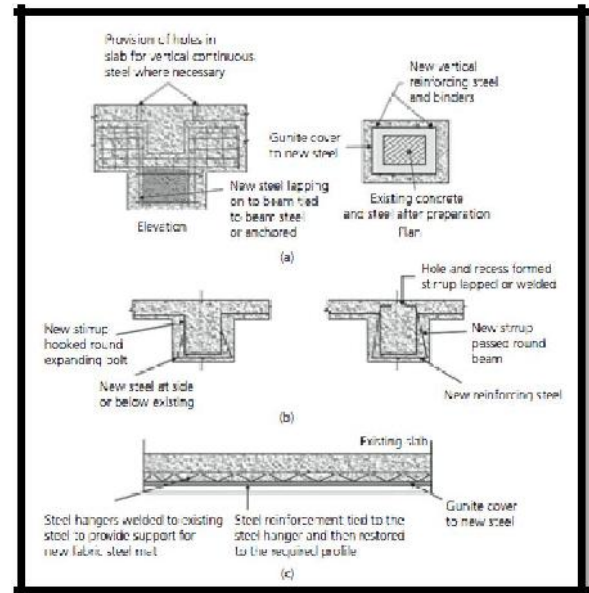

Retrofitting of Foundations are Under-pinning and Jacketing with increase in area.

Under-Pinning

In this method primarily the loads are being shifted to lower soil strata which have capability to sustain additional load. Needle & Pile underpinning of walls, Angle piling and Jack pile methods for

Figure 7: Needle Under Pinning of Wall

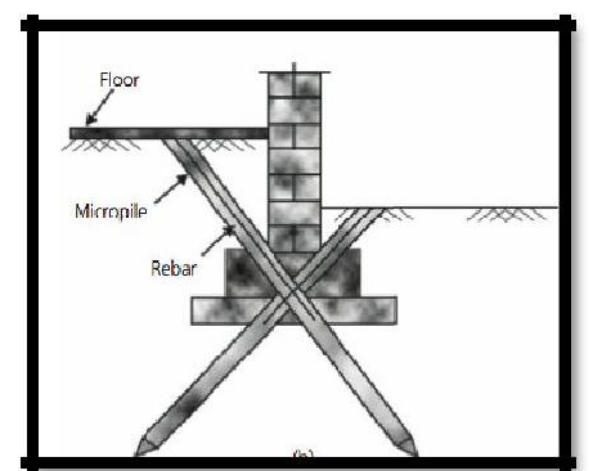

column foundations are some effective methods under the head.

Jacketing of Foundation with Increase in Area

When the soil strata is capable of sustaining additional load, generated due to contingencies like construction of additional floor etc, additional layer of reinforced concrete is laid underneath existing footing and cross-sectional area is increased with concrete jacketing.

STRENGTHENING OF COLUMNS, BEAMS AND SLABS

Columns, beams and slabs are important concrete elements of the superstructure of a

Figure 8: Transfer of Load to Lower Soil Strata

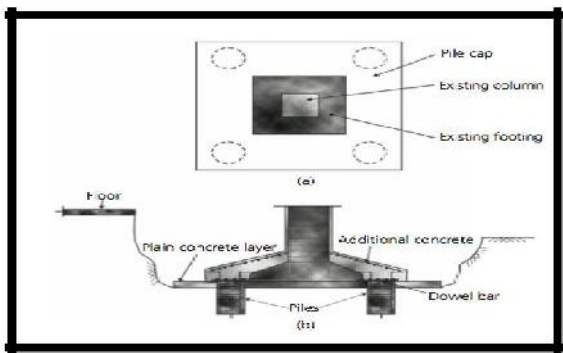
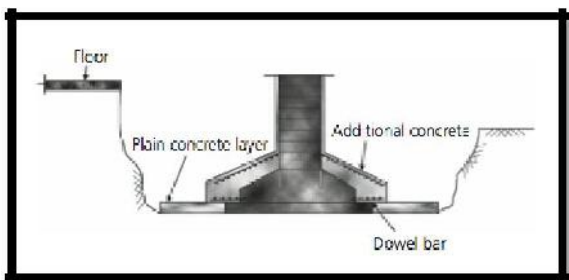

Figure 9: Method to Increase Contact Area of Foundation with Top Jacketing



framed buiding. Exposure and corrossion of reinforcement due to spalling of concrete are the common symptom in various distressed structures in India. The proven methods of Patch repair and Guniting can be employed for all, Concrete and Steel Jacketing are the methods primarily used for strengthening of the columns (and Beams in certain cases).

Patch Repair

In case of localised damage, the deteriorated concrete is removed and cleaned surface of the reinforcement bar (where corrossion has not started or in the initial stages) is coated with epoxy after cleaning/de-rusting by sand blasting/brushing/rust removers), prior to application of the epoxy mortar/polymer modified slurry is the gaps/pores/cracks. The entire surface is sealed off with the surface coating.

Guniting

The well known process of Guniting involves spraying of pressurised wet concrete mix through

Figure 10: Steps for Patch Repair of Isolated Deteriorated Pockets in RCC Elements

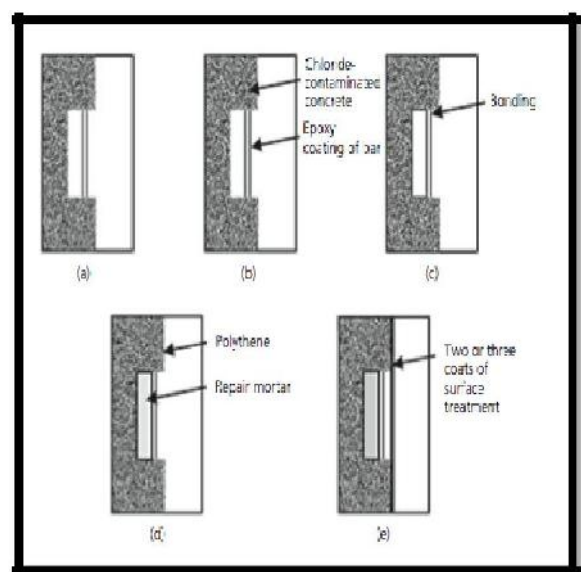

the nozzle of the Guniting machine. Prior to this, additional reinforcement is laid and connected to the existing reinforcement through drilling and welding.

The author was part of the team which reconstructed a Bailey bridge on Uri–Muzzafarabad axis in 2004. The bridge was constructed on the piers of the old bridge which was destroyed during 1948. The piers were strengthened by Guniting after additional reinforcement was laid in the surface of existing piers.

Jacketing of Columns/Beams

Jacketing remains one of the most effective method of strngthening of the existing columns. Although Partial jacketing can be employed where the existing columns are structurally sound or other constraints however due to complexity of execution and to avoid damage to the column, complete jacketing are resorted to in most of the cases.

Circular, Rectagular or Square Jacketing can be undertaken based on cross section of the existing column. Figures 12 and 13 shows how the Concrete and Steel Jacketing are carried out in practice.

Figure 11: Partial Concrete Jacketing

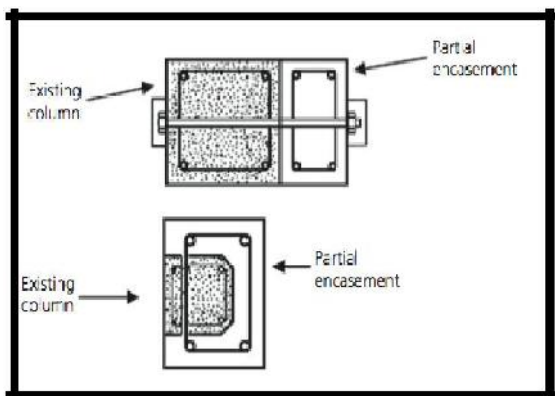

Figure 12: Steel Jacketing

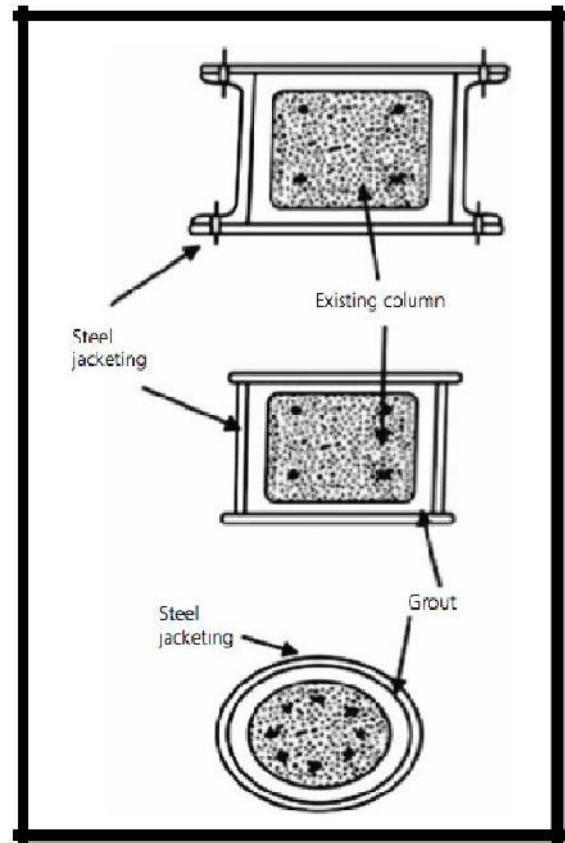
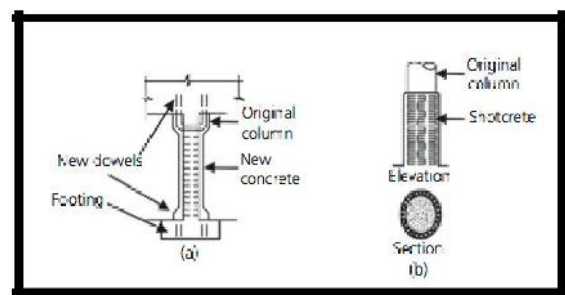

Figure 13: Concrete Jacketing



In case of steel jacketing requiring ‘Through-Bolting’ a ferro-scan is carried out before drilling for the bolt, such that existing reinforcement are not damaged in the process.

In the ambit of modern day construction, there have been various changes in the end user

Figure 14: Steel Jacketing of Beam and Column at Trump Tower, Mumbai



requirements during the construction phase itself, which requires additional loads to be borne by the constructed columns not designed for such loads. Steel jacketing of such columns enhances their capacity as has been the case of Super high rise building of Trump Tower presently under construction in Mumbai.

CASE STUDIES IN INDIA

Retrofitting is the term which is usually associated with the structural changes with respect to catering for the Lateral loads like Earthquake load in the existing buildings. With equally challenging task of Repair/ Rehabilitation of the old distressed building, successful case studies, relevant to the Indian context are not readily available.

Listed below are few successful case studies which can immensely help the civil engineers, while searching for references in regard to visual

symptoms, tests to be conducted and remedial measures.

Double Storey Residential Building, Mumbai

Details

Constructed – 1965

Investigated – 1998

Repaired – 2000

Performance – Satisfactory Post Repair

Symptoms

- Cracking/spalling of concrete in sunshades, staircases and beams.
- Reinforcement exposed/corroded heavily in some places.
- Severe seepage in roof slabs and external walls.
- De-lamination in waist slab of staircase and soffit of beams.
- No settlement in foundation.

Investigations

- Delamination Survey
 - To measure hollowness in structural elements.
 - Medium hammer providing details from 15-25 mm found effective.
 - All columns and beams tested.
- Rebound Hammer Test and Ultrasonic Pulse Velocity Tests
 - To measure internal uniformity/strength of concrete elements.
 - Rebound Hammer Test – Result Range 25-30.
 - UPV Test- Result Range 2-2.5 Km/sec.

Figure 15: Visible Spalling of Concrete



- Half Cell Potentiometer Test
 - To measure corrosion in steel.
 - Potential difference measured in grids in respect to one reference point.
 - Resultant contour maps gives indication of the severity of corrosion.
 - Regions with 90% corrosion probability showed -350 to -450 mV potential difference.
- Carbonation Test
 - To measure depth of carbonation in concrete.

Figure 16: Corrosion of Exposed Reinforcement



- Phenolphthalin solution sprayed and cross section analysed for loss of alkalinity.
- Alkalinity loss noted well beyond reinforcement depth.

Findings for the Probable Causes

- Excessive chloride content found in the concrete.
- High humidity and hot climate aided deterioration in the concrete.
- High Carbon di oxide and other pollutants in the environment.
- Quality of cover concrete was found inadequate.

Remedial Measures Undertaken

- Dismantling of sunshades and walls on the balcony, staircases and damaged beams and replacement with Prefabricated Light weight bricks.
- Fresh concreting replacing damaged concrete applying epoxy based bonding material at the junctions (Temporary supports provided during replacement).
- Cracks in the RCC pressure grouted with Epoxy based material.

Figure 17: Corrosion of Rebars at Joints



Figure 18: Repair of External Cracks with Polymer Modified Mortar

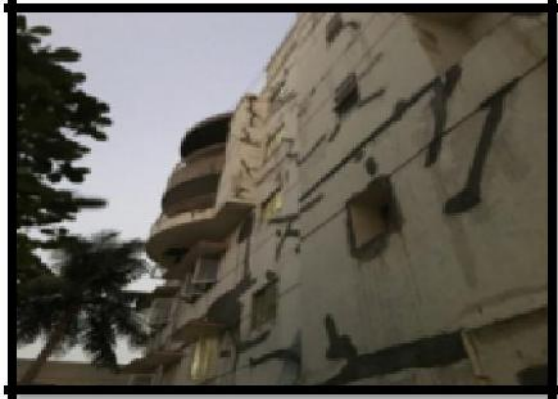

- Spalled concrete repaired with polymer based mortar/concrete after applying epoxy bond coat.
- Complete surface coating with cement based paint with polymer compound.

G+8 Residential Building, ONGC Colony, Chandkheda, Gujrat

Details

- Constructed – 1989-90
- Investigated – 2001
- Repaired – 2003
- Performance – Satisfactory Post Repair till 2012, certain distress symptoms re-appeared thereafter.
- Building already displaying distress symptoms further subjected to Bhuj Earthquake 2001.

Symptoms

- Vertical cracks in columns along line of concrete cover.
- Cracks in masonry walls at Ground floor.
- Spalling of concrete in beams, columns, slabs and fins.

Figure 19: Vertical Cracks Along Concrete Cover Line



- Stirrups exposed and severely corroded at various places.
- No settlement in foundation.

Investigations

- Rebound hammer test and core test
 - Rebound hammer test – Result range 11.2-32.6 N/mm
 - Core test – Result compressive strength range 16.52-26.17 N/mm
- Ultrasonic pulse velocity tests
 - 34 columns and 6 beams tested.

Figure 20: Corrossion of Stirrups



- Results of 6 columns found doubtful to fair.
- Only 25% of tested columns showed adequate consistency in quality (CV<5%).
- Results of all beams found satisfactory.
- Concrete near junctions found of poor quality.
- Chloride Test
 - Water soluble chloride content of the spalled concrete tested in laboratory.
 - Chloride content was found in the range of 1.84 – 1.06 g/Kg whereas permissible quantity is <0.25 g/Kg as per IS 456:2000.
- Carbonation Test
 - Average Results for columns – 78 mm (Cover – 40 mm).
 - Average Results for beams – 35 mm (Cover – 25 mm).
 - Carbonation penetration was found beyond the cover provided.

Findings for the Probable Causes

- The building was planned for M20 concrete however lower compressive strength assessed at various places.
- Earthquake resulted in further cracks and deterioration to the structure.
- Inconsistency in concrete quality indicated poor quality control during construction.
- High values of Carbonation depth indicated substantial corrosion attributed to carbonation.
- Earthquake resulted in further cracks and deterioration to the structure.

Figure 21: Cracks After Earthquake



Remedial Measures Undertaken

- Removal of visible spalled concrete in excess of 25 mm from the edges.
- Rust remover applied on the exposed rebars and wire brushed after 24 hours.
- Wherever steel cross section reduced over 20% due to corrosion, new reinforcement welded on both sides.
- As stirrups were considerably corroded, new stirrups were welded in 'U' shape.
- Cement and Acrylic Polymer slurry in 1:1 ratio, mixed with water used as Bonding Coat.
- The trial mix of Polymer Modified Mortar based as per CBRI, Roorkee guidelines and

Figure 22: Repair with Polymer Modified Mortar



Figure 23: Concrete Jacketing



approved design mix were: Cement 50 Kg: Sand (Zone II) 150 Kg:Acrylic Polymer 10-12 Kg and water in W/C ratio <math><0.4</math>.

- Concrete Column Jacketing with Micro-concrete (RMC) of 75 mm thickness (Aggregate 6-10 mm, W/C ratio 0.21, Compressive strength 30 Mpi).
- Masonary wall cracks addressed with SBR Polymer grout.
- RCC elements and joints cracks addressed with Epoxy grout from Araldite (100 g GY257, 21 g Aradur 21 and 4 g Aradur 2958).

Figure 24: Epoxy Grouting



RCC Overhead Tank, Siliguri, West Bengal

Details

- 50000 Gallon RCC tank of 9.3 x 9.3 x 3.4 m
- 16 Columns of 300 x 300 mm
- Lateral bracings at three levels of 250 x 250 mm
- Constructed – 1977-78
- Investigated – 1996 (No record drawings were available)
- Repaired – 1998
- Performance – Satisfactory Post Repair

Symptoms

- Cracking/Spalling of concrete and corrosion of steel in bracings and columns.
- Spalling at the bottom and horizontal cracks noticed in bracings.
- Spalling at the corners and vertical cracks noticed in columns.
- De-lamination in waist slab of staircase and soffit of beams.
- Storage tank was found in sound condition except partial corrosion on top slab and minor Seepage from bottom of tank.
- No tilting/settlement in foundation.
- There was fast progress in deterioration once first symptoms noticed in 1994.

Findings for the Probable Causes

- Spalling of concrete due to carbon induced corrosion.
- Severe climate aided deterioration in the concrete.

- Inadequate bonding between concrete and reinforcement at the overlapping zones due to high concentration of steel.
- Thickness of cover concrete was found inadequate.
- Immediate repairs were required to obviate sudden failure.

Remedial Measures Undertaken

- All damaged concrete removed all around using electric cutter and pneumatic chippers.
- Existing steel de-rusted using brushing and rust removers.
- Wherever steel cross section reduced over 20% due to corrosion, new reinforcement welded on both sides.
- Spalled concrete repaired with polymer based mortar/concrete after applying epoxy bond coat.
- Epoxy based coating applied on both old concrete and steel and allowed to dry properly.
- Damaged concrete portions (depth of damage > 75 mm) were replaced with fresh polymer based concrete (Cement-100, Quartz sand-200, Aggregate 20mm or below-400, Polymer-15 and Water-35 parts by weight).
- Other places Polymer Modified Mortar was used (Cement-100, Quartz sand-400, Polymer-15, Water-30 parts by weight).
- 20 mm thick plaster of cement mortar (1:4) was used to increase cover to the reinforcement.
- Sequence of repair was of very critical to avoid failure during the work.
 - Phase 1 – All bracing repaired in groups.

- Phase 2 – Columns were repaired four at a time (After load were transferred to ground through steel props under repaired bracings).

G+3 Residential Building, Basant Nagar, Tamil Nadu

Details

- Exact Dates not available
- Building constructed in near proximity to sea shore and exposed to saline environment.

Symptoms

- Similar symptoms to the other cases including spalling, corrosion of rebars, cracks, etc.
- Traces of dampness underneath slabs.

Investigations

- Similar to previous case studies.
- Rebound Hammer Test and Core Test.
- Half Cell Potentiometer Test
- Carbonation Test
- Chloride Penetration Test

Findings for the Probable Causes

- Proximity to sea shore and exposure to saline environment aided deterioration.
- No prior treatment of reinforcement bars.

Figure 25: Spalling and Corrosion



- Quality of concrete tested and found satisfactory except high chloride content.
- Chloride penetration was considerable and removal of entire affected concrete was not feasible.

Remedial Measures Undertaken

- Similar to previous case studies.
- Use of Polymer Modified Mortar for replacing spalled concrete.
- Rust removal, treating and welding of new rebars as required.
- Epoxy pressure grouting.
- Concrete jacketing of affected columns.
- Surface sealing.
- In addition to the above two new methods were adopted during the rehabilitation; GFRP protection for the columns and Cathodic protection for the rebars.
- Glass Fibre Reinforced Polymer (GFRP) uniaxial sheets were wrapped around the affected columns after concrete jacketing to improve ductility and energy absorption capacity. The columns were finished with sand pellet layering.

Figure 26: Application of PMM on Roof



Figure 27: GFRP Wrapping of Columns



Figure 28: Sacrificial Zinc Anode



- As chloride penetration was considerable, the protection to rebars against corrosion was provided by provisioning of sacrificial Zinc anodes.

CONCLUSION

Prima facie the visual distress symptoms and repair techniques of the deterioration due to old vintage, environmental conditions and inadequate quality control during construction appear similar. The further assessment of damage is required to be undertaken deliberately with the help of NDTs and chemical testing in the laboratories, prior to deciding the remedial measures. It is logical outcome that rehabilitation/ retrofitting is a specialized task and be undertaken with due diligence. The risks of covering up the symptoms are considerable and importance of maintaining

proper records of such occurrences and remedial measures will lead to proper engineering solutions to the challenge at hand.

REFERENCES

1. Bhattacharjee J (2018), "Deterioration of Concrete Structures Along with Case Studies in India", Proceedings of Institute of Civil Engineers, Forensic Engineering.
2. CPWD (2011), "Repairs and Rehabilitation of RCC Buildings", CPWD, Government of India, New Delhi, India.
3. Varghese P C (2014), *Book on Maintenance, Repair/Rehabilitation and Minor Works of Buildings*, PHI Learning Pvt. Ltd., New Delhi, India.
4. Varinder K Singh (2012), "Structural Repair and Rehabilitation of 3 No. (G+8) Multi-Storeyed Residential Buildings, at ONGC Colony at Chandkheda, Ahmedabad, Gujrat", *Procedia Engineering*, Science Direct, Vol. 5, pp. 55-56.
5. Vidiivelli B (2014), "Rehabilitation of Concrete Structures", Standard Publishers Distributors, Nai Sarak, Delhi, India.
6. Vijayalakshmi R (2017), "Case Study on the Repair and Rehabilitation of G+3 Residential Appartment Located Near Sea Shore, Tamil Nadu, India", *Indian Journal of Science and Technology*.



International Journal of Engineering Research and Science & Technology

Hyderabad, INDIA. Ph: +91-09441351700, 09059645577

E-mail: editorijerst@gmail.com or editor@ijerst.com

Website: www.ijerst.com

